

# QG12C 切管机中英文爆炸图 (QG12C Pipe Cutter Spare Part List)

## 机架部件 (110) -76100 Machine Body Complete

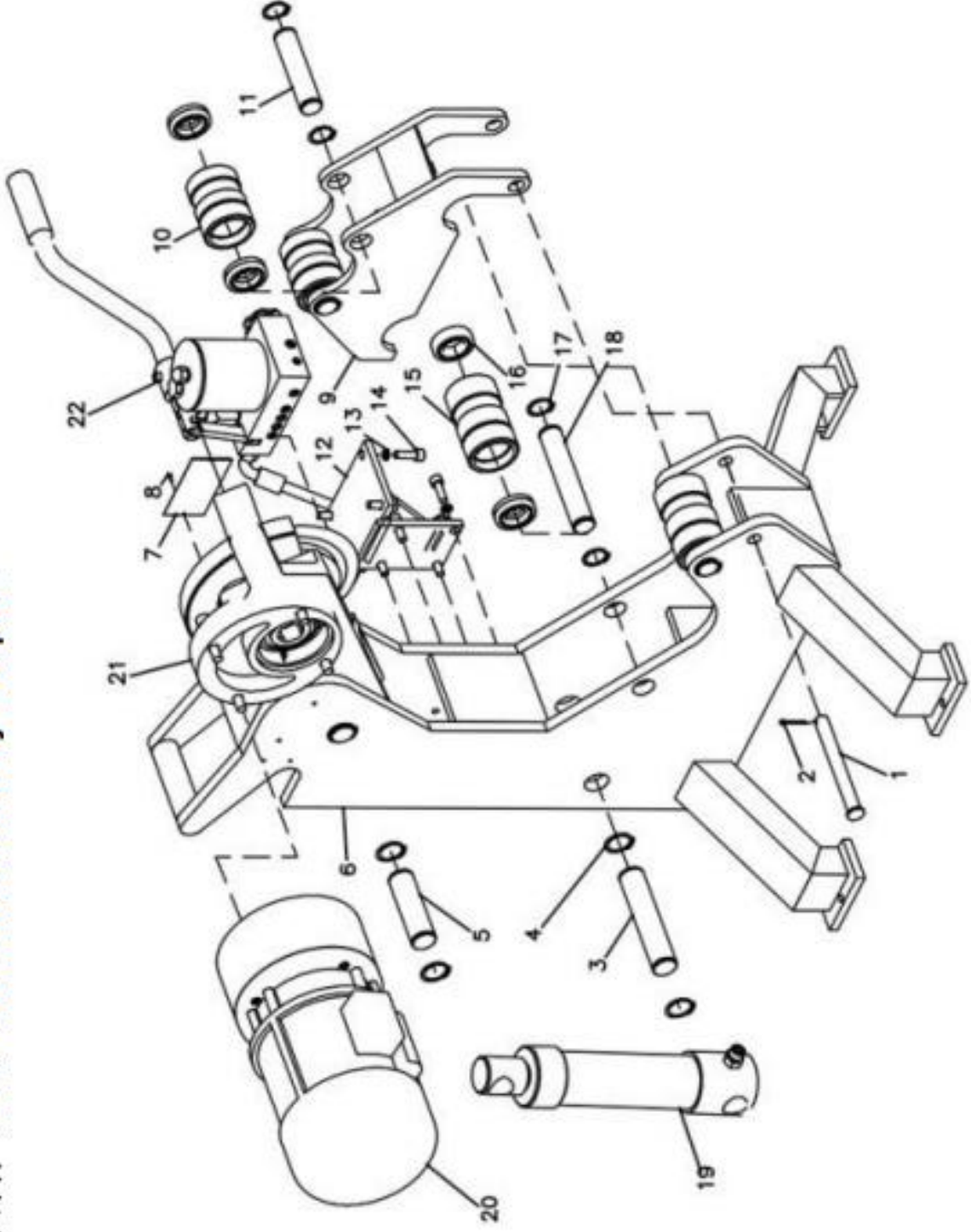
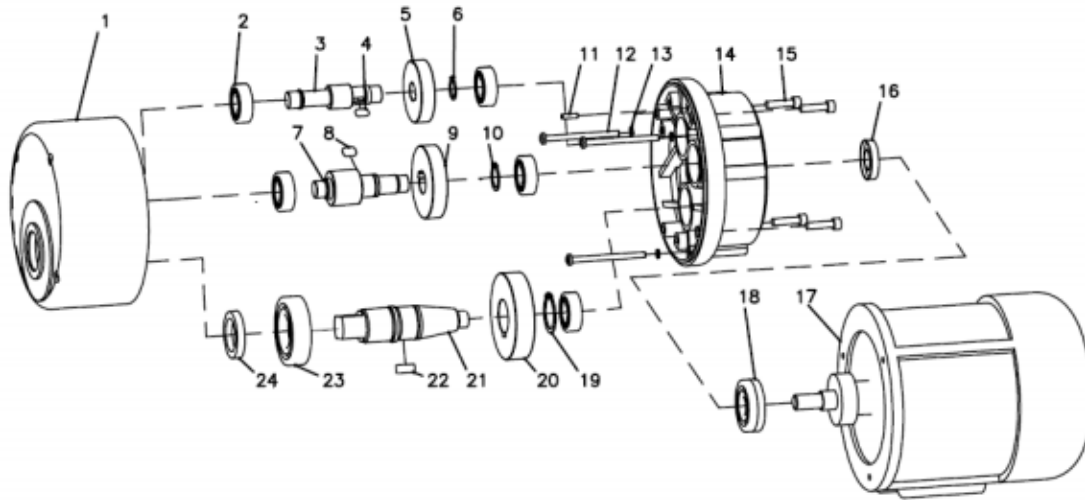

S/N	Ref. No.	品名	Description
1	42002038	支轴 III	Shaft
2	50105060	开口销 4*32	Clip4*32
3	42002036	支轴 I d=28 (2)	Shaft d=28
4	50108032	A 型轴用挡圈 28 (6)	Retaining ring 28
5	42002040	支轴 II d=28	Cylinder pin d=28
6	40103002	机架	Frame
7	40801006	切管机铭牌	Nameplate
8	50104003	铆钉 2.5*6 (2)	Rivet
9	40103007	小管支架	Upper roller hub
10	41503030	短滚轮	Upper roller
11	42002039	短滚轮轴 (2)	Upper roller pin
12	40903001	泵座	Pump rest
13	50107019	垫圈 8 (8)	Gasket 8
14	50103034	螺钉 M8*25 (8)	Screw M8*25 (8)
15	41503031	长滚轮 (2)	Lower roller
16	50401014	轴承 6005-2RZ (8)	Bearing
17	50108031	A 型轴用挡圈 d=25 (8)	Retaining ring d=25
18	42002035	长滚轮轴 d=25 (2)	Roller pin d=25
19	10902001	油缸总成	Cylinder complete
20	10503001	变速箱部件 (电机齿轮箱总成)	Gear box complete with motor
21	10806001	割刀臂总成	Cutter arm complete
22	10901005	手动泵总成-208A	Pump complete
	10901006	QG12C 脚踏泵总成	Foot pump complete

**减速机部件 ( 308) Mortor & Gearbox Complete**

S/N	Ref. No.	品名	Description
1	40302049	减速机箱体/变速箱体	Gear housing
2	50401008	轴承 6202-2RZ (5)	Bearing
3	40205070	I 级齿轴	1st gear shaft
4	50106005	平键 5×5×12	Key 5×5×12
5	40202049	高速齿轮	Hi-speed gear
6	50108025	A 型轴用挡圈 d=16	Retaining ring d=16
7	40205071	II 级齿轴	2nd gear shaft
8	50106013	平键 6×6×12	Key 6×6×12
9	40202050	中速齿轮	M-speed gear
10	50108028	A 型轴用挡圈 d=20	Retaining ring d=20
11	50105006	B 型圆柱销 4×16	Roll pin 4×16
12	50103077	十字槽盘头螺钉 M5×70 (3)	Screw M5×70
13	50107017	标准型弹簧垫圈 d=5 (3)	Spacer d=5
14	40302048	电机端前盖	Motor front cover
15	50103020	内六角圆柱头螺钉 M6×25 (4)	Screw M6×25 (4)
16	50803005	唇型密封圈 B30×42×7	Seal B30*42*7
17	30401056	电机	Motor
18	50401023	轴承 6303-2RZ	Bearing
19	50108033	A 型轴用挡圈 d=30	Retaining ring d=30
20	40202048	低速齿轮	L-speed gear
21	40206035	输出轴	Output shaft
22	50106019	平键 8×7×17	Key 8×7×17
23	50401018	轴承 6206-2RZ	Bearing
24	50803001	唇型密封圈 B17×35×7	Seal B17*35*7
	30402039	开关	Switch

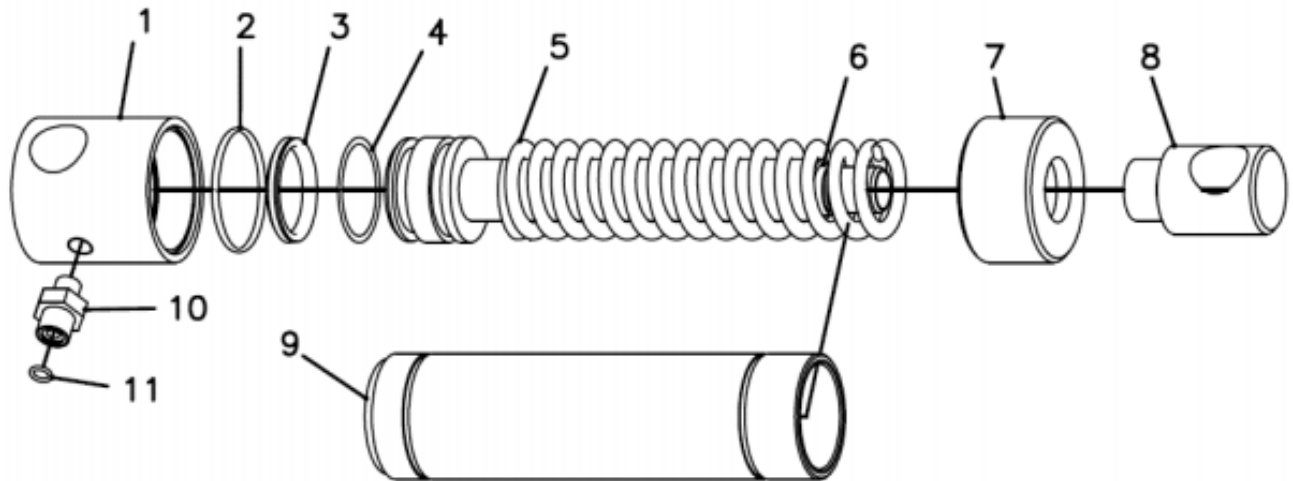
**油缸部件 (407) -75400 Oil Cylinder Complete**

S/N	Ref. No.	品名	Description
1	40903002	底座	Cylinder base
2	50801033	O 型密封圈 56×3.55	O ring 56*3.55
3	50802012	孔用 Y 型密封圈 D50	Y ring D50
4	50801043	O 型密封圈 50×43.7×1.5	O ring 50*43.7*1.5
5	50702025	压缩弹簧	Compression spring
6	42002037	活塞杆	Piston rod
7	41901029	钢盖	Steel cover
8	41801053	液压顶头	Connector
9	41705072	缸体	Cylinder
10	40401069	油管接头	Hose connector
11	50801003	O 型密封圈 7.5×18	O ring

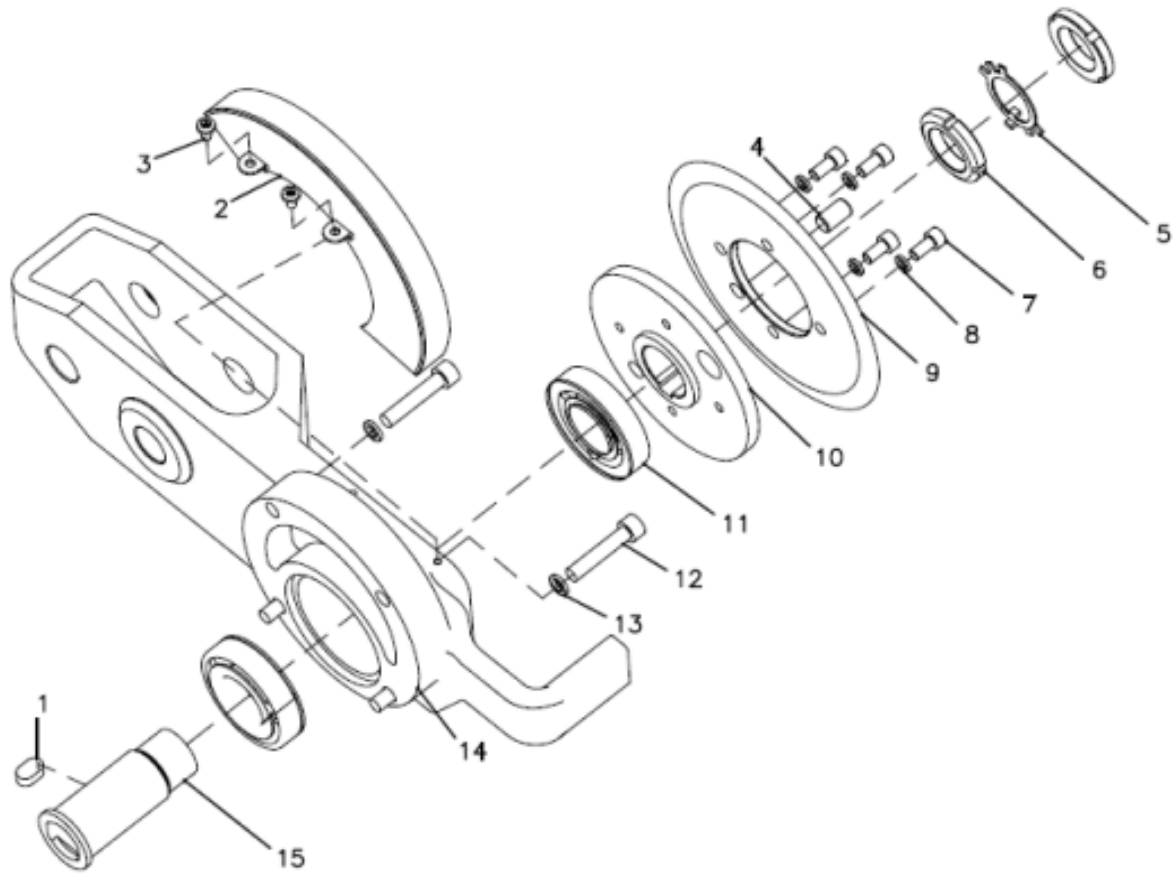
**割刀臂部件 (604) -76600 Pipe Cutter Pivot Arm Complete**

S/N	Ref. No.	品名	Description
1	50106025	平键 12×8×20	Key 12×8×20
2	40103005	罩壳	Wheel guard
3	50103070	十字槽盘头螺钉 M5×10 (2)	Screw M5×10 (2)
4	50105024	圆柱销 13×22	Pinφ13*22
5	50107025	止动垫圈 36	Gasket 36
6	50102025	圆螺母 M36×1.5 (2)	Locking nut
7	50103031	螺钉 M8×16 (4)	Screw M8×16 (4)
8	50107019	垫圈 M8	Spacer
9	40601012	割刀片	Cutting wheel
10	41801054	割刀座	Wheel hub
11	50401042	圆锥滚子轴承 30208 (2)	Needle bearing
12	50103051	内六角圆柱头螺钉 M10×50	Screw M10×50
13	50107020	垫圈 M10 (4)	Spacer
14	40304041	割刀臂	Pivot arm
15	42002041	割刀轴	Drive shaft

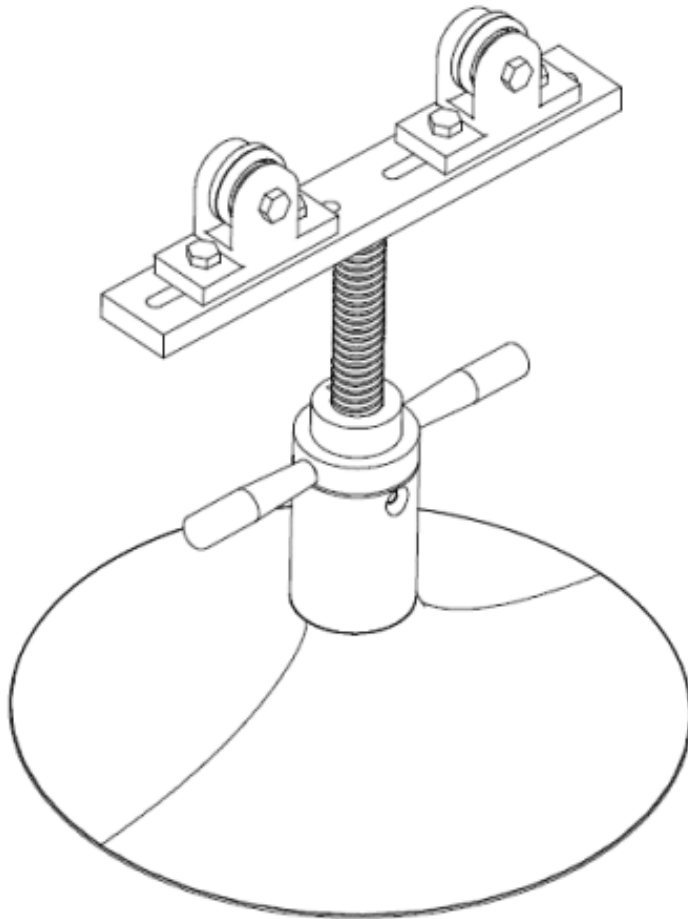
**管支架部件（658）--65500 Pipe Support Complete**

S/N	Ref. No.	品名	Description
1	11002011	1105 支架(厂内型号 658)	Pipe support