

OPERATION & MAINTENANCE INSTRUCTION MANUAL

Vane-type Water Flow Detectors, Saddle Connection

Specifications (UL/FM):

Service Pressure: 450psi
Flow Sensitivity Range for Signal: 15-37.8L/min (4-10GPM)
Contact Ratings: 8A at 125/250VAC; 3A at 24VDC; 2.5A at 30VDC
Operating Temperature Range: 0°C-49°C
Compatible pipe: steel pipe, schedule 10 ~ 40
Maximum Surge: 18FPS (5.5m/s)



Specifications (CE):

Service Pressure: 16bar
Flow Sensitivity Range for Signal: 30-57L/min
Contact Ratings: 8A at 125/250VAC; 3A at 24VDC;
Operating Temperature Range: 0°C-68°C
Maximum Surge: 18FPS (5.5m/s)

UL/ULC Listed, FM Approved, and CE Certification

CAUTION!

Vane-type water flow detectors that are monitoring wet pipe systems shall not be used in dry pipe, deluge, or pre-action systems. The surges of water in such systems may break the vane or damage the mechanism. Do not use in potentially explosive atmospheres.

General Information

Water flow detectors are mounted to water-filled pipes in sprinkler systems. It is used on steel pipe, schedules 10 through 40, sizes 50mm thru 200mm (2" thru 8"). See Table 1 for detectors sizes.

Water flow in the pipe deflects a vane, which triggers a switch usually after a specified delay period. All water flow detectors have a pneumatically controlled mechanical delay mechanism. Delays reset if the flow of water stops before the entire delay has elapsed. All switches are actuate when the water flow rate is 10 gallons per minute or greater, but will not actuate if the rate is less than 4 gallons per minute. This installation manual covers the following water flow detectors for sprinkler.

Table 1 Detectors sizes

| Nominal Pipe Size | | Model | Max. Pressure Rating(psig) |
|-------------------|------|-------|----------------------------|
| DN50 | 2" | F6001 | 450 |
| DN65 | 2.5" | F6001 | 450 |
| DN80 | 3" | F6001 | 450 |
| DN100 | 4" | F6001 | 450 |
| DN125 | 5" | F6001 | 450 |
| DN150 | 6" | F6001 | 450 |
| DN200 | 8" | F6001 | 450 |

OPERATION & MAINTENANCE INSTRUCTION MANUAL

Vane-type Water Flow Detectors, Saddle Connection

Installation Guidelines

NOTE: Do not leave cover off for an extended period of time.

1. These devices may be mounted on horizontal or vertical pipe. On horizontal pipe they shall be installed on the top side of the pipe where they will be accessible. Be sure there is adequate clearance for installation and removal. See Fig.1 for mounting dimensions.
2. The device should not be installed within 15cm of a fitting which change the direction of the water flow or within 60cm of a valve or drain
3. Drain the system and drill a hole in the pipe. And be sure the hole is perpendicular to the center of the pipe, as show in Fig.2. If the hole is off center, the vane will bind against the inside wall of the pipe. Use a hole saw in a slow speed drill to cut a hole of the proper diameter, as show in Table 2.
4. Remove burrs and sharp edges from the hole. Clean and remove all scale and foreign matter from the inside of the pipe for a distance equal to the pipe diameter on either side of the hole. Clean the outside of the pipe to remove dirt, metal chips, and cutting lubricant.
5. Roll the vane so that it may be inserted into the hole; do not bend or crease it. Seat the gasket against the saddle and mount the detector into the pipe. Insert the vane so that the arrow on the saddle points in the direction of the water flow. The bushing should fit inside the hole in the pipe.
6. Install the U-bolt and tighten nuts alternately to ensure a uniform seal (see the Table 2 for torque values).

Fig.1 Mounting dimensions

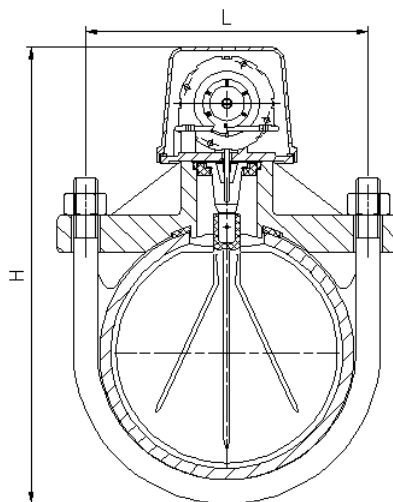
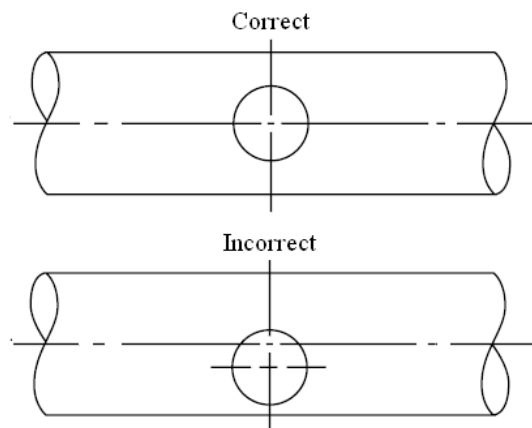

Fig.2 Mounting hole location



7. The vane must not rub the inside of the pipe or bind in any way. If the vane binds, remove the detector and correct the cause before proceeding.
8. Ensure that the direction of arrow on the saddle point should be consistent with the direction of the water flow. See Fig.3.

Notes: Remove burrs from edge of hole. Clean out scale and foreign matter from inside wall of pipe.

OPERATION & MAINTENANCE INSTRUCTION MANUAL

Vane-type Water Flow Detectors, Saddle Connection

Table 2 Main dimensions

| Nominal Pipe Size | | Nominal Pipe Size OD. | | Pipe wall thickness | | | | L | H | Hole size | U-Bolt Nuts torque |
|-------------------|-----|-----------------------|-------|---------------------|-------|------------|-------|-----|-----|-----------|--------------------|
| | | | | Schedule10 | | Schedule40 | | | | | |
| mm | in | mm | in | mm | in | mm | in | mm | mm | mm | Nm |
| DN50 | 2 | 60.3 | 2.375 | 2.77 | 0.109 | 3.91 | 0.154 | 84 | 188 | 32+1 | 40-50 |
| DN65 | 2.5 | 73.0 | 2.875 | 3.05 | 0.12 | 5.16 | 0.203 | 92 | 200 | | |
| DN80 | 3 | 88.9 | 3.500 | 3.05 | 0.12 | 5.49 | 0.216 | 104 | 220 | 51+1 | 70-95 |
| DN100 | 4 | 114.3 | 4.500 | 3.05 | 1.12 | 6.02 | 0.237 | 133 | 245 | | |
| DN125 | 5 | 141.3 | 5.563 | 3.40 | 0.134 | 6.55 | 0.258 | 160 | 272 | | |
| DN150 | 6 | 168.3 | 6.625 | 3.40 | 0.134 | 7.11 | 0.280 | 187 | 298 | | |
| DN200 | 8 | 219.1 | 8.625 | 3.76 | 0.148 | 8.18 | 0.322 | 240 | 350 | | |

(This torque is only for normal use. The type test torque is recommended to be appropriately increased.)

Wiring

1. All models have two SPDT switches, one can be used to operate a central station, while the other contact is used to operate a local audible or visual annunciator. Switch contacts COM and NO are closed when water is flowing and open when it is not. Connect the switches, as shown in Fig.4, depending on the application.
2. A ground screw is provided with all water flow detectors. When grounding is required, clamp wire with screw in hole located between conduit entrance holes. See Fig.5.
3. If a second conduit entry is required, remove the knockout plug: Place screwdriver at inside edge of knockouts, not in the center.

Fig.3 Assembly diagram

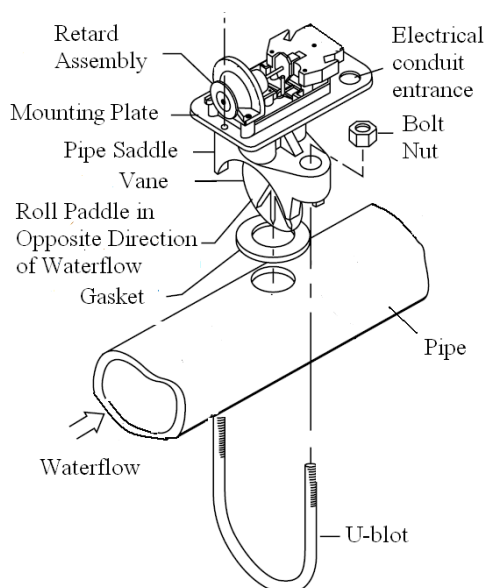
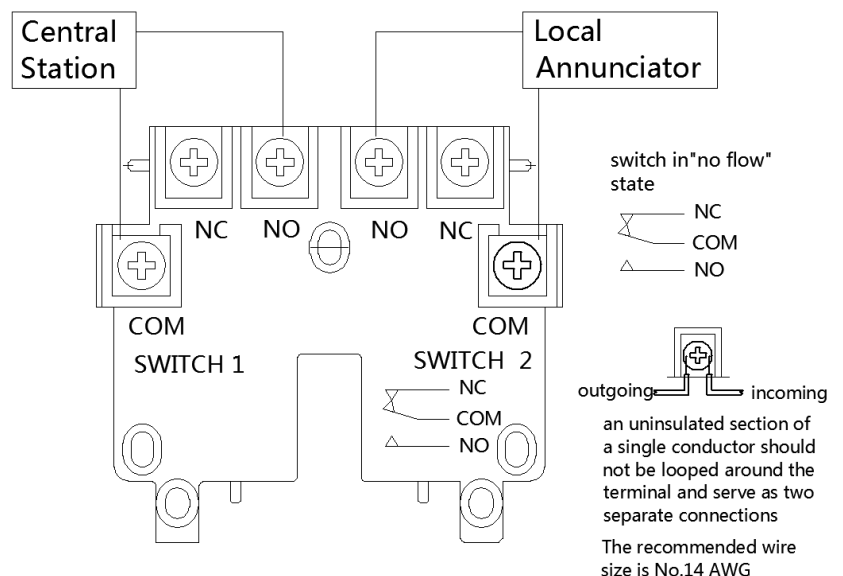

Fig.4 Typical electrical connections



OPERATION & MAINTENANCE INSTRUCTION MANUAL

Vane-type Water Flow Detectors, Saddle Connection

Retard Adjustment

The delay can be adjusted by rotating the retard adjustment knob from 0 to max setting. To adjust the setting, turn the adjustment knob clockwise to increase the delay, counterclockwise to decrease it. The time delay should be set at the minimum required to prevent false alarms.

Maintenance

Inspect detectors monthly. If leak are found, replace the detector.

Fig.5 Ground screw

